

O			
N			
M			
L			
K			
J			
I			
H			
G			
F			
E			
D			
C			
B			
A			

Issue	Revision	Date	Initial
-------	----------	------	---------

Notes:
All dimensions in inches

ESC Client:

Manufacturer:
ESC STEEL LLC
18805 W. Catawba Ave
Suite 207
Cornelius
NC 28031
USA

T : (980) 689-4388
Email : info@escsteel.com

Project Title:



Drawing Title:
ESC-CRZ14-650

Stamp: Signature:

MANUFACTURING DRAWING

Designed LILI	Drawn SAMUEL	Checked BRUCE	Rev. A
Scale	Date 2020.09.14	Job No.	

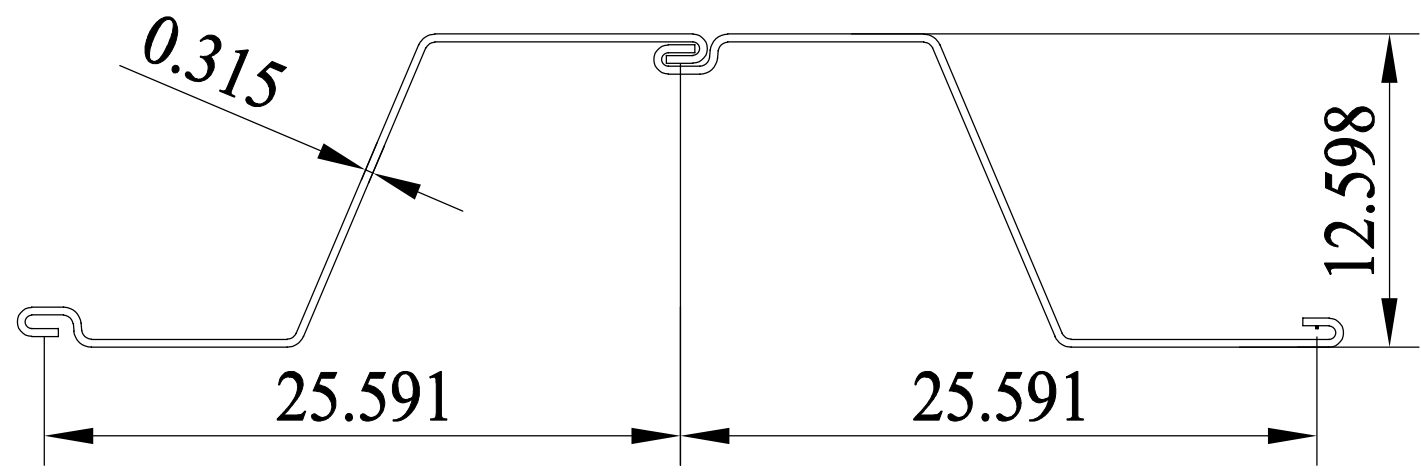

ESC-CRZ14-650

COMBINED PILE PROPERTIES								
SERIES	UNIT WIDTH W [in] (mm)	HEIGHT H [in] (mm)	THICKNESS t [in] (mm)	MASS [lb/ft] (kg/m)	MASS [lb/ft ²] (kg/m ²)	TOTAL MODULUS [in ³ /ft] (cm ³ /m)	TOTAL MOMENT OF INERTIA [in ⁴ /ft] (cm ⁴ /m)	Coating Area both side [ft ² /ft] (m ² /m)
CRZ 14-650	25.591 (650)	12.598 (320)	0.315 (8.0)	43.1 (64.11)	20.2 (98.63)	26.1 (1402)	163.7 (22431)	6.76 (2.06)