

O			
N			
M			
L			
K			
J			
I			
H			
G			
F			
E			
D			
C			
B			
A			

Issue	Revision	Date	Initial
-------	----------	------	---------

Notes:  
All dimensions in inches

ESC Client:

Manufacturer:  
ESC STEEL LLC  
18805 W. Catawba Ave  
Suite 207  
Cornelius  
NC 28031  
USA  
T : (980) 689-4388  
Email : info@escsteel.com

Project Title:



Drawing Title:  
**ESC-CRZ22-700**

Stamp: \_\_\_\_\_ Signature: \_\_\_\_\_

**MANUFACTURING DRAWING**

Designed LILI	Drawn SAMUEL	Checked BRUCE	Rev. A
Scale	Date 2020.09.14	Job No.	

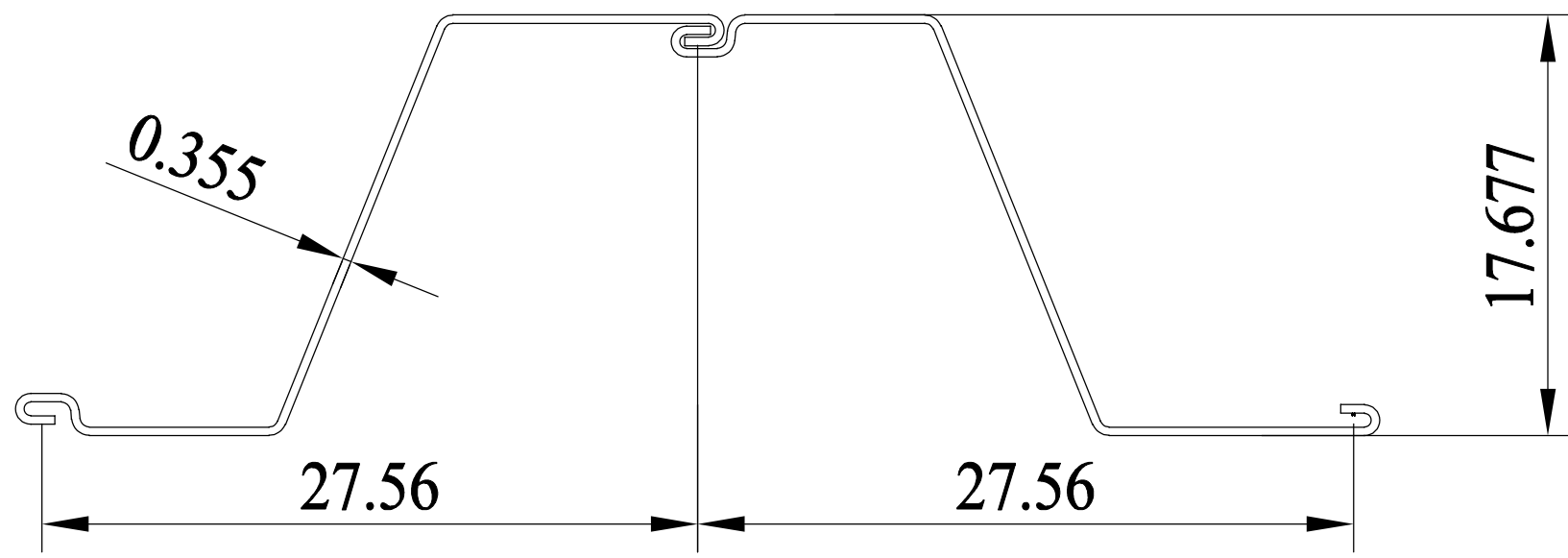

**ESC-CRZ22-700**

COMBINED PILE PROPERTIES								
SERIES	UNIT WIDTH W [in] (mm)	HEIGHT H [in] (mm)	THICKNESS t [in] (mm)	MASS [lb/ft] (kg/m)	MASS [lb/ft²] (kg/m²)	TOTAL MODULUS [in³/ft] (cm³/m)	TOTAL MOMENT OF INERTIA [in⁴/ft] (cm⁴/m)	Coating Area both side [ft²/ft] (m²/m)
CRZ 22-700	27.56 (700)	17.677 (449)	0.355 (9.0)	55.33 (82.33)	24.09 (117.62)	41.85 (2250)	368.7 (50509)	7.71 (2.35)