

C			
N			
M			
L			
K			
J			
I			
H			
G			
F			
E			
D			
C			
B			
A	Initial Revision	7.3.11.15	JLY
Issue	Revision	Date	Initial

Notes:  
**All dimensions in millimetres**

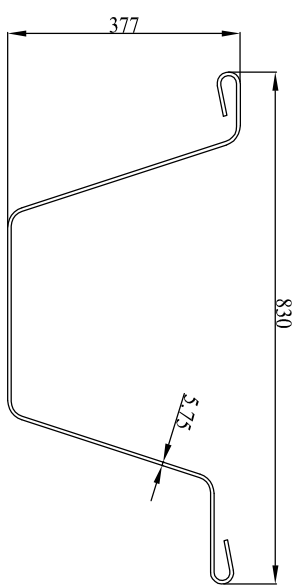

**SHEET PILE PROFILE**

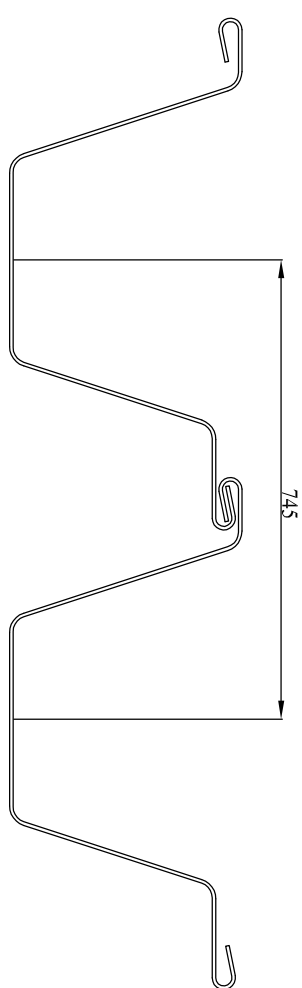

**INTERLOCKED PROFILE**

COMBINED PILE PROPERTIES								
SERIES	UNIT WIDTH W [in] (mm)	HEIGHT H [in] (mm)	THICKNESS t [in] (mm)	MASS [lb/ft] (kg/m)	MASS [lb/ft <sup>2</sup> ] (kg/m <sup>2</sup> )	TOTAL MODULUS [in <sup>3</sup> /ft] (cm <sup>3</sup> /m)	TOTAL MOMENT OF INERTIA [in <sup>4</sup> /ft] (cm <sup>4</sup> /m)	Coating Area both side [ft <sup>2</sup> /ft] (m <sup>2</sup> /m)
ESC-C-CFW12	29.33 (745)	14.84 (377)	0.23 (5.75)	45.49 (67.7)	18.65 (90.9)	22.7 (1,220)	170.44 (23,350)	11.88 (3.62)

Manufacturer:  
**ESC Group**  
 Room 209, Dongdu International, No.651  
 East 2nd Ring Road,  
 Piao Di Hut, Shuanghui, China  
 Postcode:200082  
 P1 : +86-21-31263901 Fax : +86-21-31263902  
 Email : escglobal@escpile.com

Project Title:



Drawing Title:  
**ESC-C-CFW12 SHEET PILE  
 PROFILE DRAWING**

Stamp: \_\_\_\_\_  
 Signature: \_\_\_\_\_

**PROFILE DRAWING**

Designed JLY	Drawn JLY	Checked CHK	Drawing No.	Rev.
Scale NTS	Date 13.11.2015	Job No. -		A