

**SHEET PILE PROFILE**

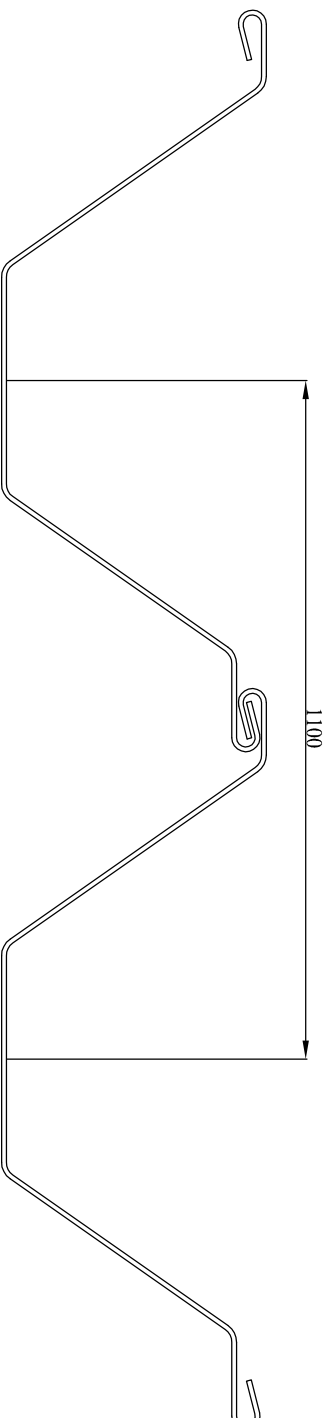

**INTERLOCKED PROFILE**

**COMBINED PILE PROPERTIES**

SERIES	UNIT WIDTH W [in] (mm)	HEIGHT H [in] (mm)	THICKNESS t [in] (mm)	MASS [lb/ft] (kg/m)	MASS [lb/ft²] (kg/m²)	TOTAL MODULUS [in³/ft] (cm³/m)	TOTAL MOMENT OF INERTIA [in⁴/ft] (cm⁴/m)	Coating Area both side [ft²/ft] (m²/m)
ESC-C-CFWM15	43.35 (1,101)	16.91 (430)	0.31 (7.76)	73.58 (109.5)	20.41 (99.5)	27.7 (1,486)	233.14 (31,940)	9.74 (2.97)

C			
N			
M			
L			
K			
J			
I			
H			
G			
F			
E			
D			
C			
B			
A			
Issue	Revision	Date	Initial
	1/15	13.11.15	JLY

Notes:  
All dimensions in millimetres

ESC Client:

Manufacturer:

**ESC Group**  
Room 302, Donggu International No.651  
East Shuang Road,  
Fuzhou District, Shuangjial, China  
Postcode:200082  
Ph: +86-21-37265601 Fax: +86-21-37265602  
Email: escglobal@escpile.com

Project Title:

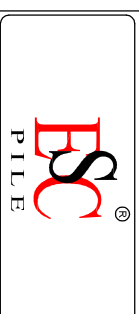

Drawing Title:  
**ESC-C-CFWM15 SHEET PILE  
PROFILE DRAWING**

Stamp: \_\_\_\_\_

Signature: \_\_\_\_\_

**PROFILE DRAWING**

Designed JLY	Drawn JLY	Checked CHK	Drawing No.	Rev.
Scale NTS	Date 13.11.2015	Job No. -		A