

O			
N			
M			
L			
K			
J			
I			
H			
G			
F			
E			
D			
C			
B			
A			

Issue	Revision	Date	Initial
-------	----------	------	---------

Notes:  
All dimensions in inches

ESC Client:

Manufacturer:  
ESC STEEL LLC  
18805 W. Catawba Ave  
Suite 207  
Cornelius  
NC 28031  
USA  
T : (980) 689-4388  
Email : info@escsteel.com

Project Title:



Drawing Title:  
**ESC-CRZ14-670**

Stamp: Signature:

**MANUFACTURING DRAWING**

Designed LILI	Drawn SAMUEL	Checked BRUCE	Rev. A
Scale	Date 2020.09.14	Job No.	

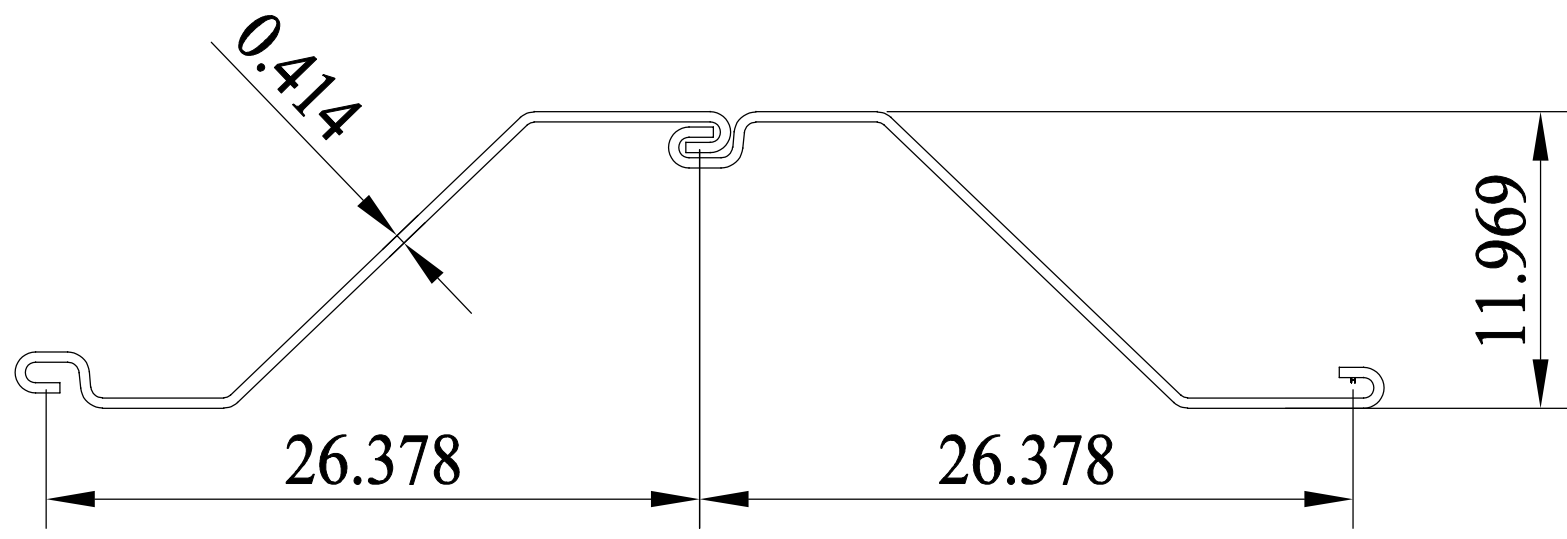

**ESC-CRZ14-670**

COMBINED PILE PROPERTIES								
SERIES	UNIT WIDTH W [in] (mm)	HEIGHT H [in] (mm)	THICKNESS t [in] (mm)	MASS [lb/ft] (kg/m)	MASS [lb/ft <sup>2</sup> ] (kg/m <sup>2</sup> )	TOTAL MODULUS [in <sup>3</sup> /ft] (cm <sup>3</sup> /m)	TOTAL MOMENT OF INERTIA [in <sup>4</sup> /ft] (cm <sup>4</sup> /m)	Coating Area both side [ft <sup>2</sup> /ft] (m <sup>2</sup> /m)
CRZ 14-670	<b>26.378</b> (670)	<b>11.969</b> (304)	<b>0.414</b> (10.5)	<b>54.76</b> (81.49)	<b>24.91</b> (121.62)	<b>25.9</b> (1391)	<b>154.4</b> (21148)	<b>6.56</b> (2.00)