

O			
N			
M			
L			
K			
J			
I			
H			
G			
F			
E			
D			
C			
B			
A			

Issue	Revision	Date	Initial
-------	----------	------	---------

Notes:  
All dimensions in inches

ESC Client:

Manufacturer:  
ESC STEEL LLC  
18805 W. Catawba Ave  
Suite 207  
Cornelius  
NC 28031  
USA  
T : (980) 689-4388  
Email : info@escsteel.com

Project Title:



Drawing Title:  
**ESC-CRZ20-700**

Stamp: Signature:

**MANUFACTURING DRAWING**

Designed LILI	Drawn SAMUEL	Checked BRUCE	Rev. A
Scale	Date 2020.09.14	Job No.	

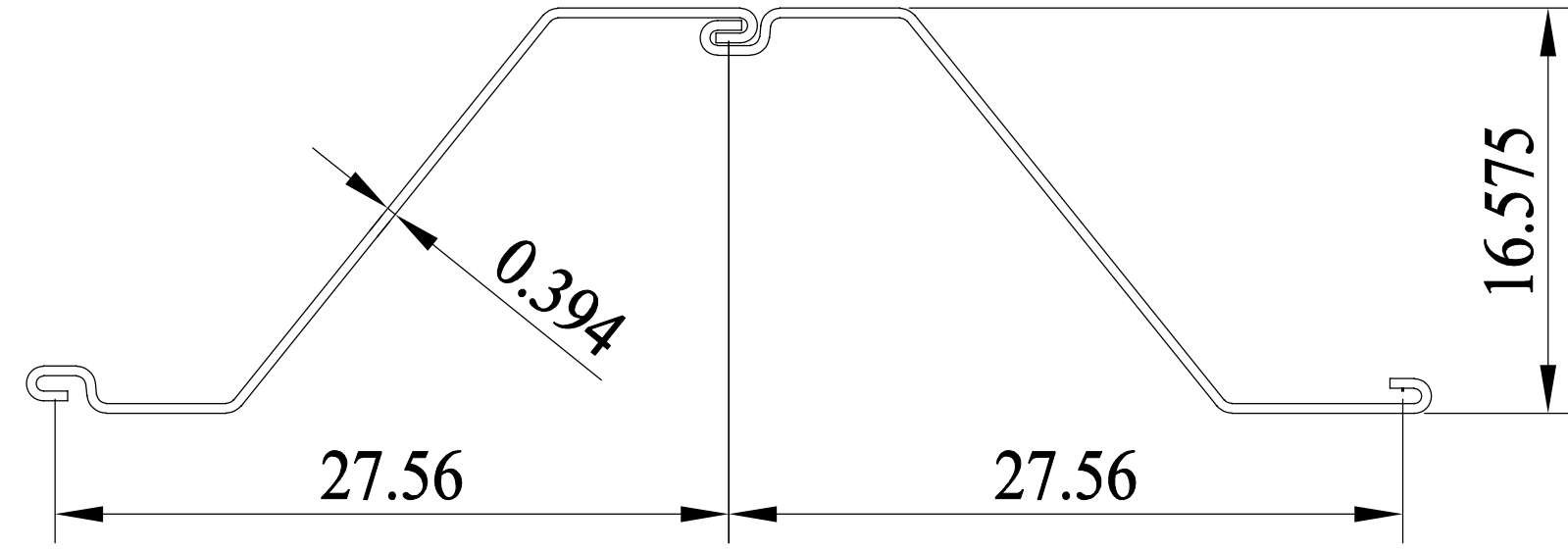

**ESC-CRZ20-700**

COMBINED PILE PROPERTIES								
SERIES	UNIT WIDTH W [in] (mm)	HEIGHT H [in] (mm)	THICKNESS t [in] (mm)	MASS [lb/ft] (kg/m)	MASS [lb/ft <sup>2</sup> ] (kg/m <sup>2</sup> )	TOTAL MODULUS [in <sup>3</sup> /ft] (cm <sup>3</sup> /m)	TOTAL MOMENT OF INERTIA [in <sup>4</sup> /ft] (cm <sup>4</sup> /m)	Coating Area both side [ft <sup>2</sup> /ft] (m <sup>2</sup> /m)
CRZ 20-700	<b>27.56</b> (700)	<b>16.575</b> (421)	<b>0.394</b> (10.0)	<b>56.72</b> (84.41)	<b>24.70</b> (120.59)	<b>36.20</b> (1946)	<b>299.0</b> (40954)	<b>7.12</b> (2.17)