

O			
N			
M			
L			
K			
J			
I			
H			
G			
F			
E			
D			
C			
B			
A			

Issue	Revision	Date	Initial
-------	----------	------	---------

Notes:
All dimensions in inches

ESC Client:

Manufacturer:
ESC STEEL LLC
18805 W. Catawba Ave
Suite 207
Cornelius
NC 28031
USA
T : (980) 689-4388
Email : info@escsteel.com

Project Title:



Drawing Title:
ESC-CRZ26-700

Stamp: Signature:

MANUFACTURING DRAWING

Designed LILI	Drawn SAMUEL	Checked BRUCE	Rev. A
Scale	Date 2020.09.14	Job No.	

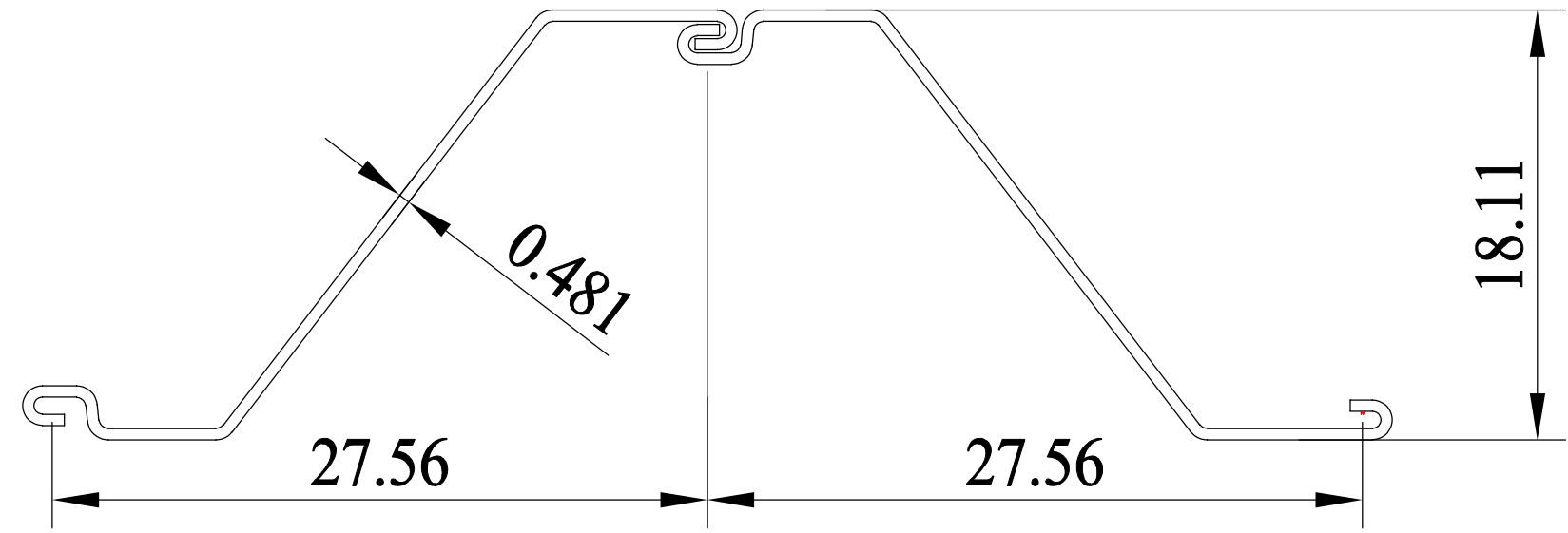

ESC-CRZ26-700

COMBINED PILE PROPERTIES								
SERIES	UNIT WIDTH W [in] (mm)	HEIGHT H [in] (mm)	THICKNESS t [in] (mm)	MASS [lb/ft] (kg/m)	MASS [lb/ft ²] (kg/m ²)	TOTAL MODULUS [in ³ /ft] (cm ³ /m)	TOTAL MOMENT OF INERTIA [in ⁴ /ft] (cm ⁴ /m)	Coating Area both side [ft ² /ft] (m ² /m)
CRZ 26-700	27.56 (700)	18.110 (460)	0.481 (12.2)	71.70 (106.70)	31.22 (152.42)	48.4 (2602)	436.8 (59838)	7.38 (2.25)