

O			
N			
M			
L			
K			
J			
I			
H			
G			
F			
E			
D			
C			
B			
A			

Issue	Revision	Date	Initial
-------	----------	------	---------

Notes:
All dimensions in inches

ESC Client:

Manufacturer:
ESC STEEL LLC
18805 W. Catawba Ave
Suite 207
Cornelius
NC 28031
USA
T : (980) 689-4388
Email : info@escsteel.com

Project Title:



Drawing Title:
ESC-CRZ28-700-12mm

Stamp: Signature:

MANUFACTURING DRAWING

Designed LILI	Drawn SAMUEL	Checked BRUCE	Rev. A
Scale	Date 2020.09.14	Job No.	

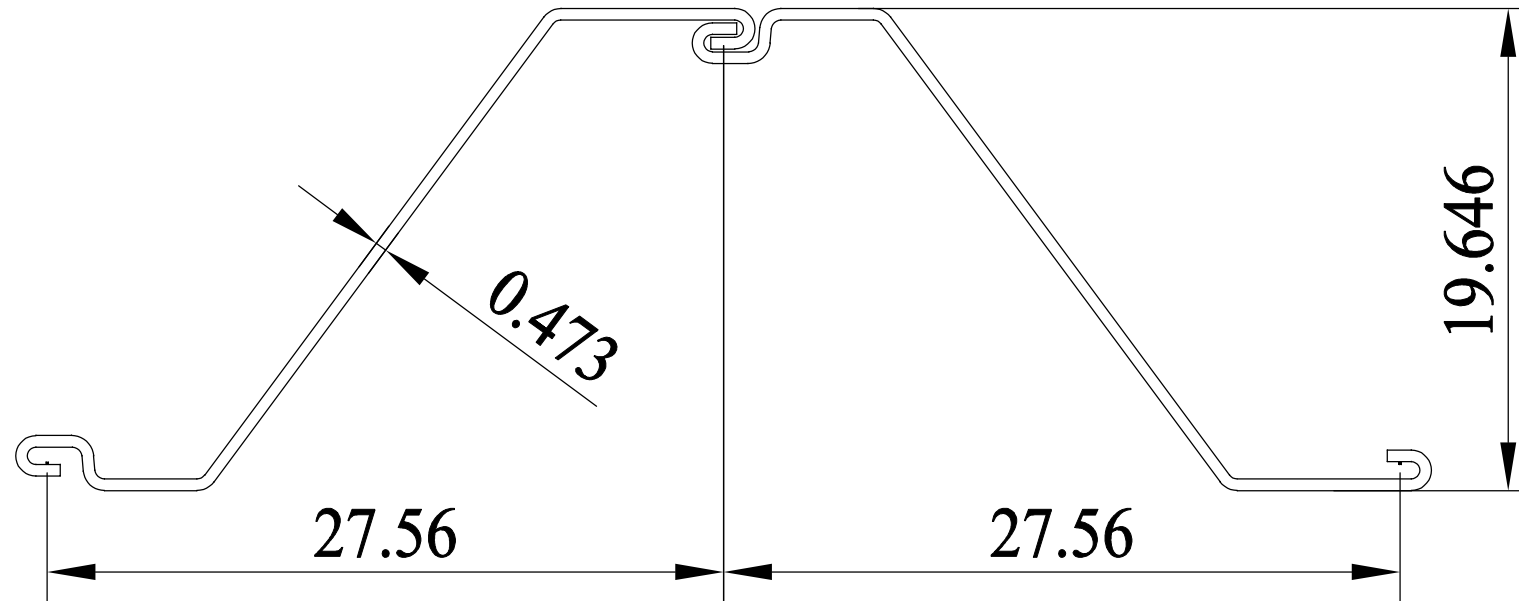

ESC-CRZ28-700-12mm

COMBINED PILE PROPERTIES								
SERIES	UNIT WIDTH W [in] (mm)	HEIGHT H [in] (mm)	THICKNESS t [in] (mm)	MASS [lb/ft] (kg/m)	MASS [lb/ft²] (kg/m²)	TOTAL MODULUS [in³/ft] (cm³/m)	TOTAL MOMENT OF INERTIA [in⁴/ft] (cm⁴/m)	Coating Area both side [ft²/ft] (m²/m)
CRZ 28-700-12mm	27.56 (700)	19.646 (499)	0.473 (12.0)	72.15 (107.36)	31.41 (153.38)	52.1 (2801)	510.2 (69896)	7.56 (2.31)